

TORR was developed by a group of people who had a wealth of knowledge in the liquid products industry and bag in box applications. They decided to fill a gap in innovation and quality in machinery solutions.

The TORR team have decades of direct hands on industry experience in BIB filling.

TORR have developed a strong capability for serving the difficult technical requirements of any liquid filling and allowing more premium liquid products to be filled into flexibles.

TORR have extended their solution and can do semi manual spouted pouch filling equipment and also beverage dispensing solutions, for both food and non food liquid products.

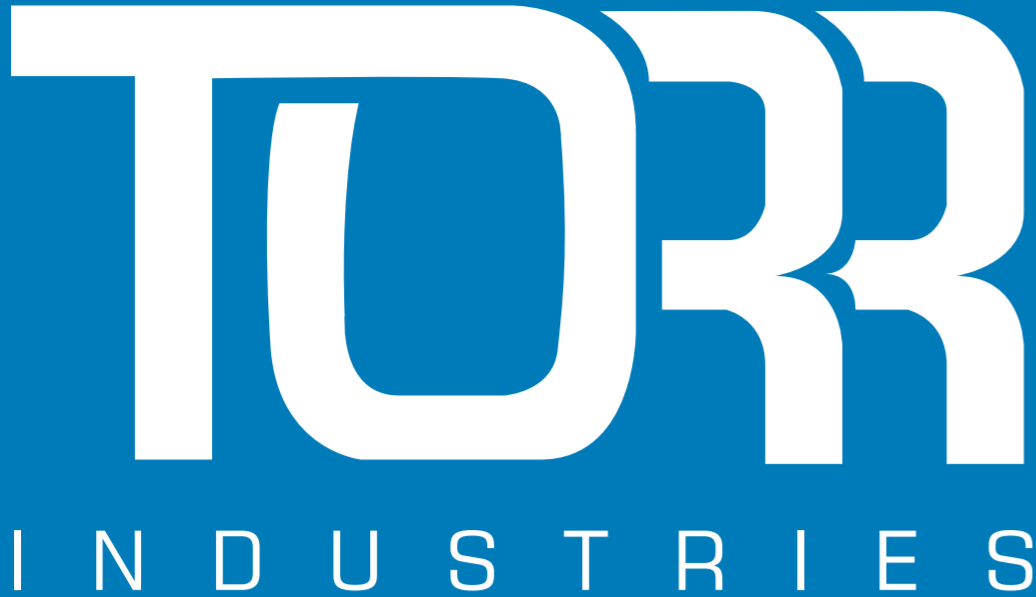

I N D U S T R I E S

INNOVATIVE LIQUID FILLING SOLUTIONS!

TORRfiller™ LIQUID FILLING SYSTEMS

- FILL BAG-IN-BOX FROM 1.5 TO 20 LITRES
- FILL STAND-UP POUCHES FROM 0.175 TO 3 LITRES
- TOOLING FOR ALL TAPS, CAPS & CONNECTORS
- FILL RATES FROM 60 TO 1500 BAGS PER HOUR

From small to large scale production. We have the filling solutions to meet your production requirements.

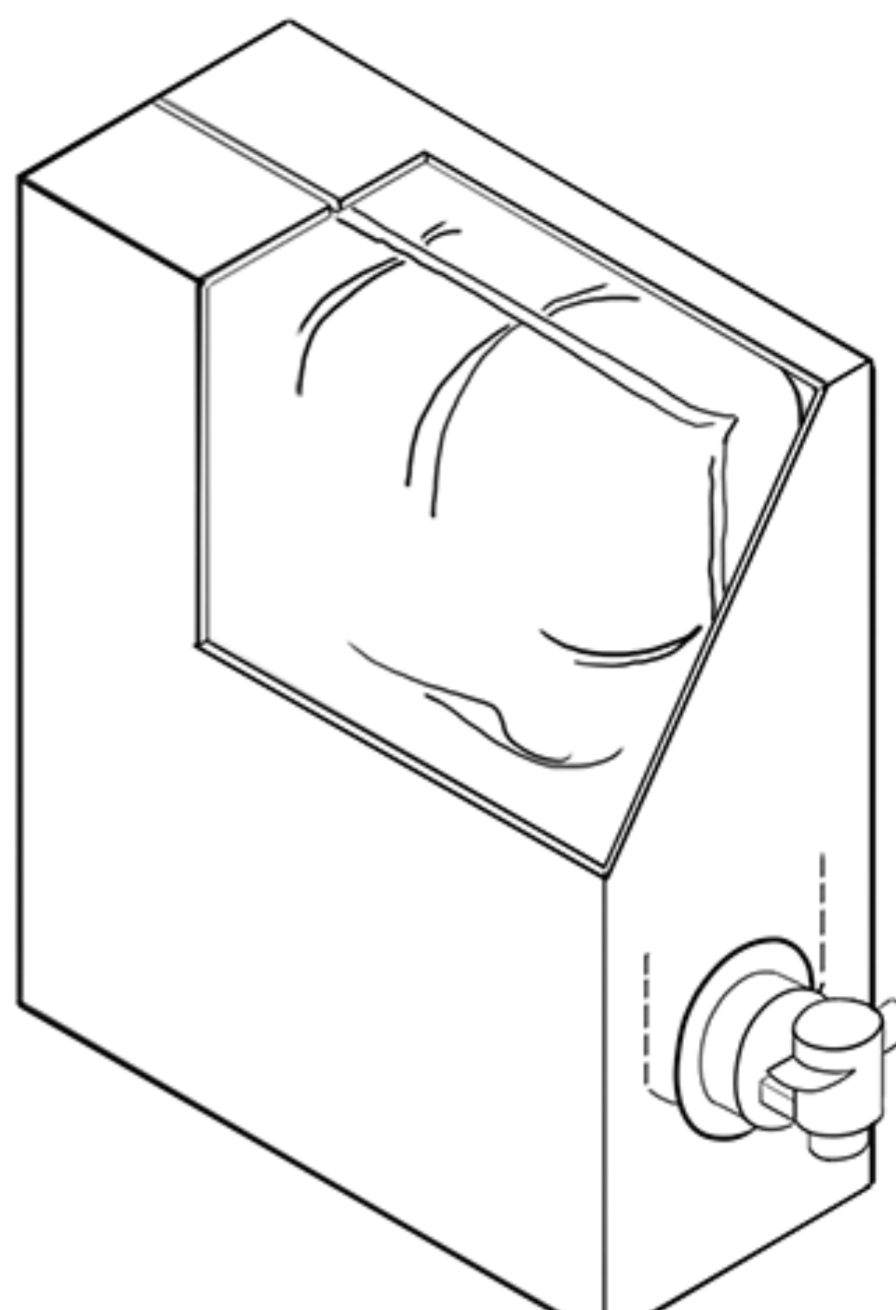

AUTOMATIC WEB FILLERS FOR BAG IN BOX

TORRfiller™ 180

A unique twin fill head assembly with a single bag infeed and box loader provides reliable and consistent filling of 3-litre bags at up to 1500 bags per hour. Servo powered.



TORRfiller™ 150

A single head version of the TORRfiller 180. Production rate is up to 960 3-Litre bags per hour. Separates bags from the web before filling. Servo powered.



TORRfiller™ 145B

Features the same servo powered fill head as the TORRfiller 150. Production rate is up to 900 3-Litre bags per hour. Separates bags after fill.



TORRfiller™ 140W

An economy automatic web feed filler with air operated fill head. The operator separates the filled bag from the web and hand loads into a box or onto a conveyor. The filler paces the operator. Production rates up to 720 bags per hour.

Available with 3-A certification for Dairy Products.



SEMI-AUTOMATIC WEB FILLERS FOR BAG IN BOX

TORRfiller™ 140H

Semi automatic pouch and bag filler. Optional Vacuum & Nitrogen purge. Rates up to 480 bags per hour. Fills from 1 to 20 litre.



TORRfiller™ 130

Semi manual pouch and bag filler. Automatic uncap and recap. Optional Vacuum & Nitrogen purge. Rates up to 240 bags per hour. Fills from 1 to 20 litre.



TORRfiller™ 110

Semi manual bag and pouch filler with turbine flowmeter. Manual uncap and recap. Optional Vacuum & Nitrogen purge. Rates up to 200 bags per hour. Fills from 1 to 20 litre.



“ Our company's success has come from our ability to solve our customer's specific liquid filling requirements. These are a only a few recent examples of our filler development capabilities. ”

Tim Orr
President TORR Industries Inc

TORR Industries products are supported in Oceania by AUSPOUCH's locally based Engineering and Sales team.

Contact Details:

Victoria

Frank Trimboli : 0412 597 178

New South Wales

Colin Keene : 0480 254 400



PACKAGING AND PROCESSING SOLUTIONS

Head Office : 02 8852 2660

www.auspouch.com.au

4, 9 Salisbury Rd Castle Hill NSW 2154